

Class AB Stereo Headphone Driver *Low Distortion, Excellent PSRR*

FEATURES

- Low supply voltage 2.8 to 5.5V
- No switch-ON/OFF clicks
- Excellent power supply ripple rejection
- Low power consumption
- Short-circuit resistant
- High performance :
 - high SNR
 - high slew rate
 - low distortion
- Large output voltage swing

APPLICATIONS

- CD-RW 、DVD-RW
- CD-ROM 、DVD-ROM
- MP3 、PDA
- Portable Digital Audio
- Cross-reference :
TDA1308T

DESCRIPTION

The MS6308 is an integrated class AB stereo headphone driver contained in an SO8 package. The device is fabricated in a CMOS process and has been primarily developed for portable digital audio applications. MS6308 is pin and function compatible with the Philips, TDA1308T.

BLOCK DIAGRAM

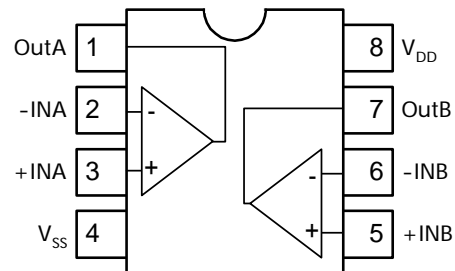

PIN CONFIGURATION

Symbol	Pin	Description
OUTA	1	Output A
-INA	2	Inverting input A
+INA	3	Non-inverting input A
V _{SS}	4	Negative supply
+INB	5	Non-inverting input B
-INB	6	Inverting input B
OUTB	7	Output B
V _{DD}	8	Positive supply

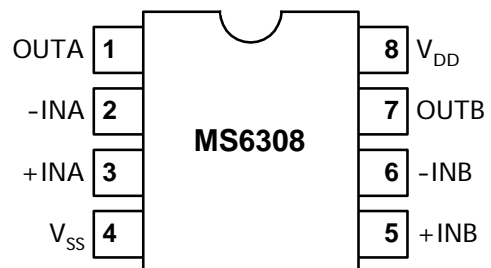

ORDERING INFORMATION

Package	Part number	Packaging Marking	Transport Media
8-Pin SOP	MS6308TR	MS6308	2.5k Units Tape and Reel
8-Pin SOP	MS6308U	MS6308	100 Units Tube
8-Pin SOP (lead free)	MS6308GTR	MS6308G	2.5k Units Tape and Reel
8-Pin SOP (lead free)	MS6308GU	MS6308G	100 Units Tube

ABSOLUTE MAXIMUM RATINGS

Symbol	Parameter	Rating	Unit
V _{DD}	Supply Voltage	7	V
V _{ESD}	Electrostatic Handling	-6000 to 6000	V
T _{STG}	Storage Temperature Range	-65 to 150	°C
T _A	Operating Ambient Temperature Range	-40 to 85	°C
T _J	Maximum Junction Temperature	150	°C
T _S	Soldering Temperature, 10 seconds	260	°C
R _{THJA}	Thermal Resistance from Junction to Ambient in Free Air SOP8	210	°C/W

OPERATING RATINGS

Symbol	Parameter	Min	Typ	Max	Unit
V _{DD}	Supply Voltage	2.8	-	5.5	V

5V ELECTRICAL CHARACTERISTICS

($T_a=25^\circ\text{C}$, $V_{DD}=5\text{V}$, $V_{SS}=0\text{V}$, $V_O=3.5\text{V}_{pp}$, $f=1\text{kHz}$, $R_L=32\Omega$; unless otherwise specified)

Symbol	Parameter	Conditions	Min	Typ	Max	Unit
DC Characteristics						
I_Q	Quiescent current	$V_O=0\text{V}_{pp}$, 2 channels	-	3.2	4	mA
V_O	Maximum output voltage swing	$(\text{THD+N})/S < 0.1\%$	3.5	4	-	V_{pp}
PSRR	Power supply rejection ratio	$V_{ripple} = -20\text{dBV}$, 100Hz	-	70	-	dB
CS	Cannel separation		-	100	-	dB
AC Characteristics						
THD+N	Total harmonic distortion plus noise	$(\text{THD+N})/S < 0.1\%$	-	-75	-67	dB
			-	0.017	0.044	%
S/N	Signal-to-noise ratio		100	110	-	dB
SR	Slew rate	Unity gain inverting	-	5	-	$\text{V}/\mu\text{s}$
P_o	Maximum output power	$(\text{THD+N})/S < 0.1\%$, 2 ch	-	124	-	mW

2.8V ELECTRICAL CHARACTERISTICS

($T_a=25^\circ\text{C}$, $V_{DD}=2.8\text{V}$, $V_{SS}=0\text{V}$, $V_O=2\text{V}_{pp}$, $f=1\text{kHz}$, $R_L=32\Omega$; unless otherwise specified)

Symbol	Parameter	Conditions	Min	Typ	Max	Unit
DC Characteristics						
I_Q	Quiescent current	$V_O=0\text{V}_{pp}$, 2 channels	-	2.3	3	mA
V_O	Maximum output voltage swing	$(\text{THD+N})/S < 0.1\%$	1.8	2	-	V_{pp}
PSRR	Power supply rejection ratio	$V_{ripple} = -20\text{dBV}$, 100Hz	-	66	-	dB
CS	Cannel separation		-	92	-	dB
AC Characteristics						
THD+N	Total harmonic distortion plus noise	$(\text{THD+N})/S < 0.1\%$	-	-70	-63	dB
			-	0.031	0.070	%
S/N	Signal-to-noise ratio		90	100	-	dB
P_o	Maximum output power	$(\text{THD+N})/S < 0.1\%$, 2 ch	-	31	-	mW

TYPICAL PERFORMANCE CHARACTERISTICS

($T_a=25^\circ\text{C}$, $R_L=32\Omega$; unless otherwise specified)

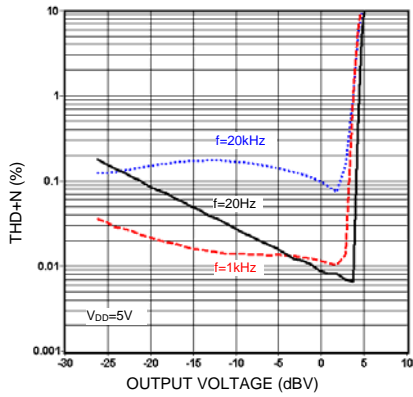

THD+N vs. output voltage

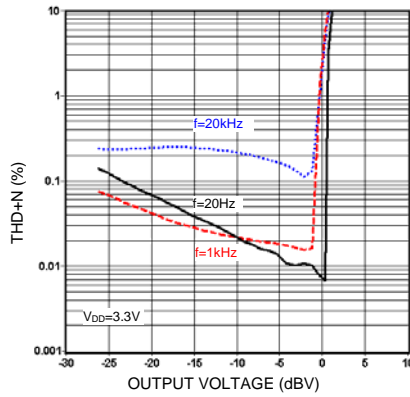

THD+N vs. output voltage

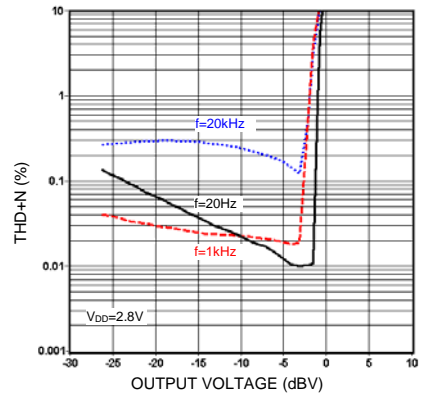

THD+N vs. output voltage

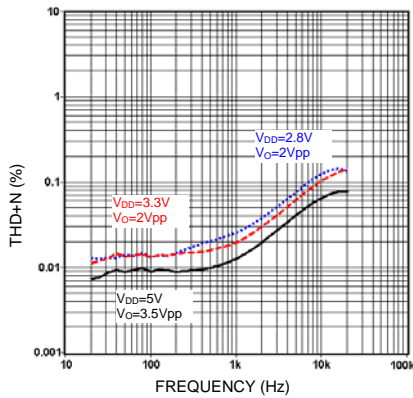

THD+N vs. frequency

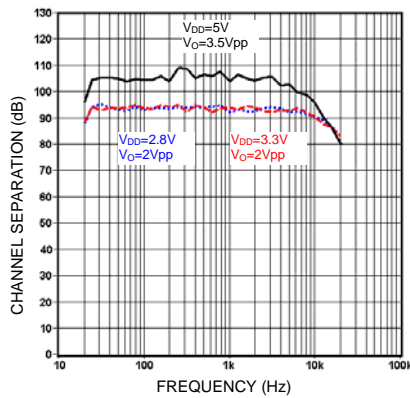

Channel separation vs. frequency

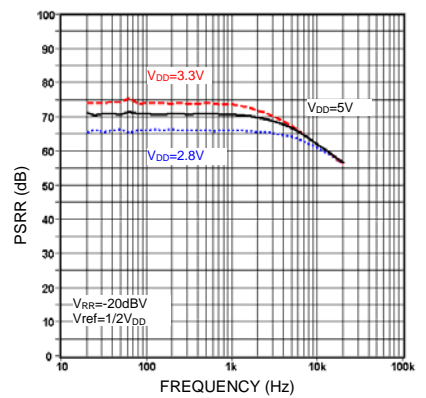

PSRR vs. frequency

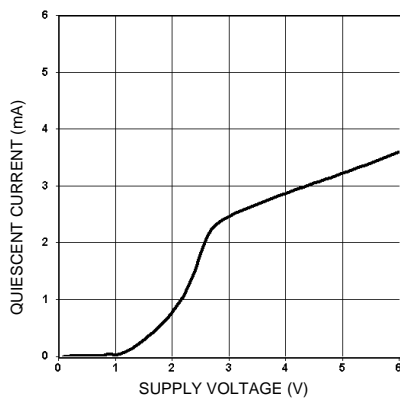

Quiescent current vs. supply voltage

APPLICATION INFORMATION

Inverting application

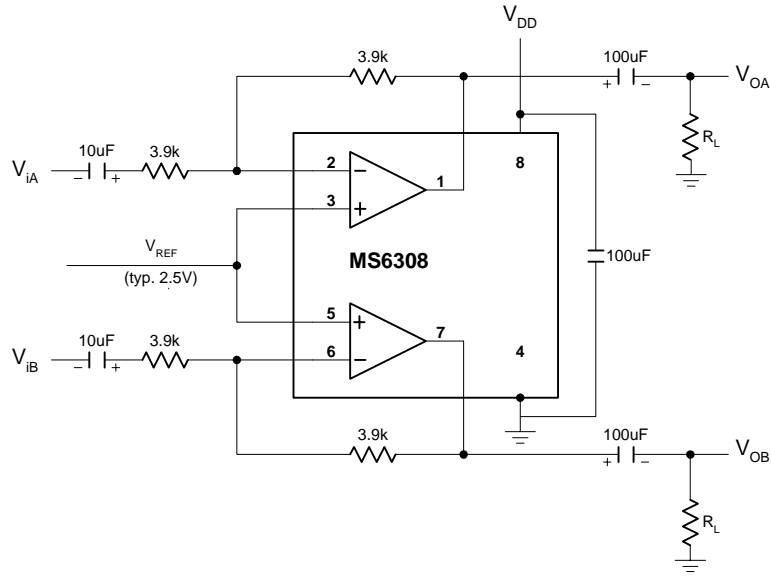

Fig.2 Measurement circuit, inverting application

Example of CD application with MS6311

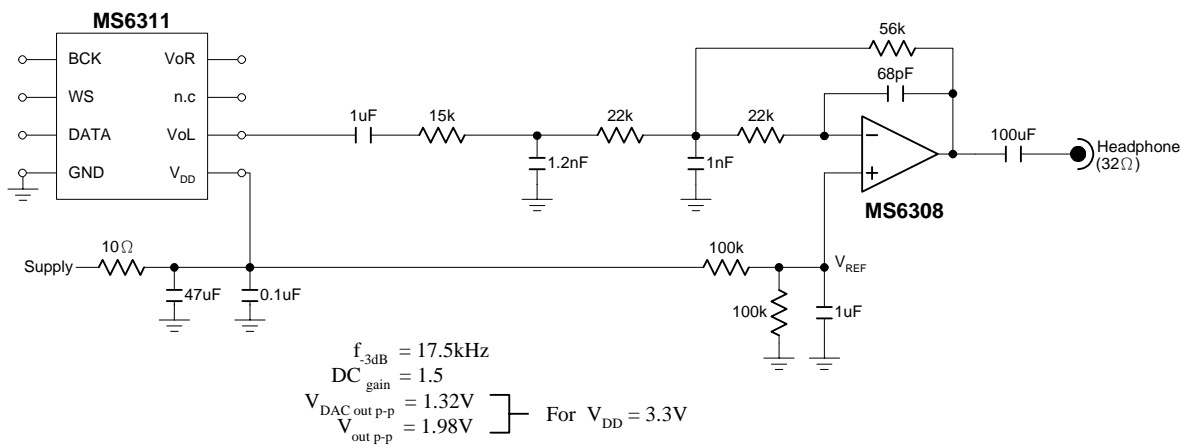

Fig.3 Example of a multiple feedback third order lowpass filter application.

MP3 digital to analog converting solution. Fig.4, Fig5

MP3 DECODER

DAC

Headphone Driver

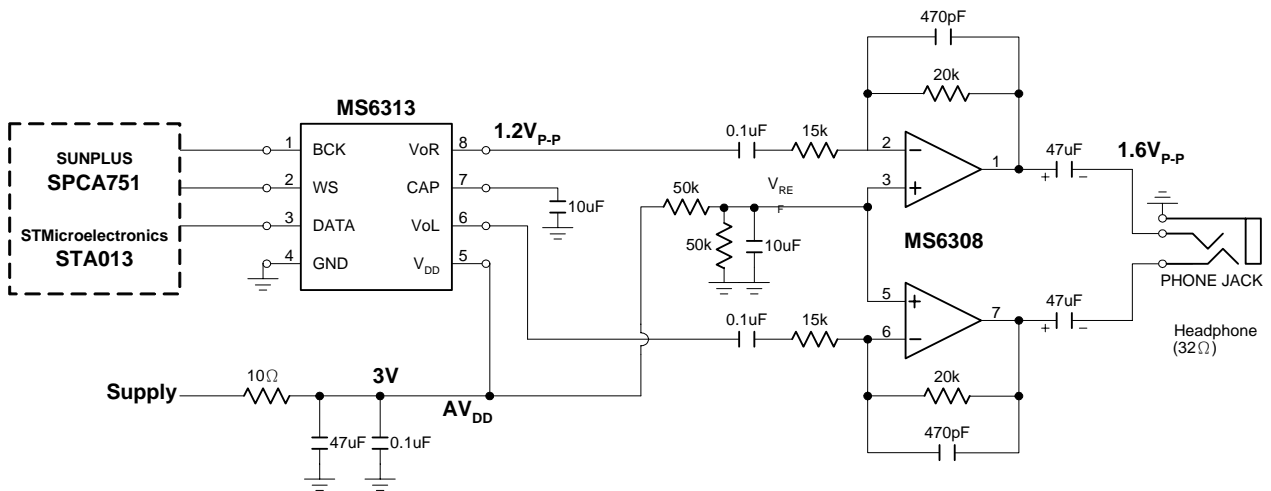

Fig.4 A first order lowpass filter for DAC output with MS6313

MP3 DECODER

DAC

Headphone Driver

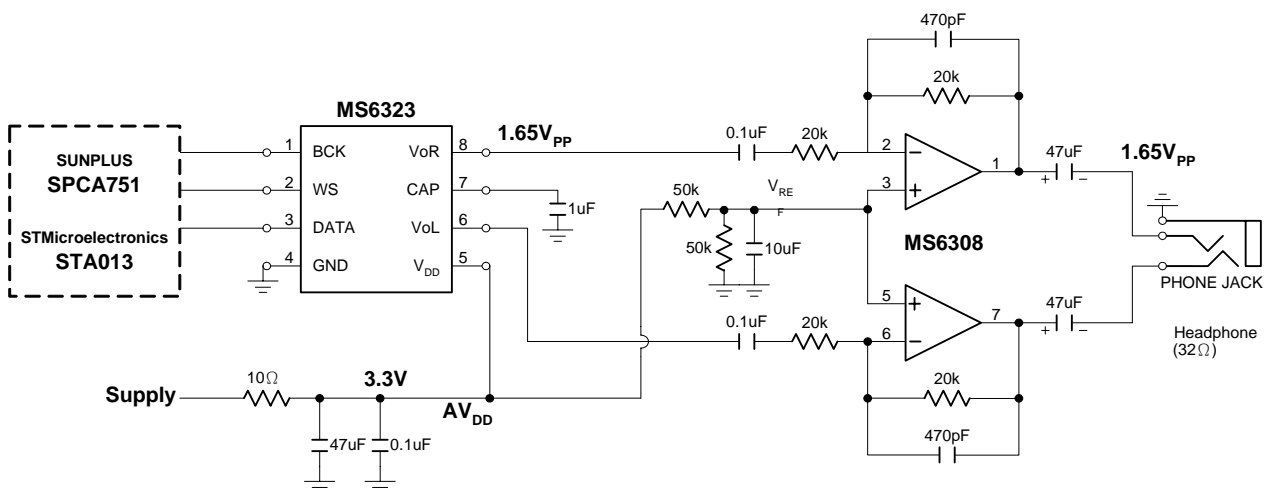
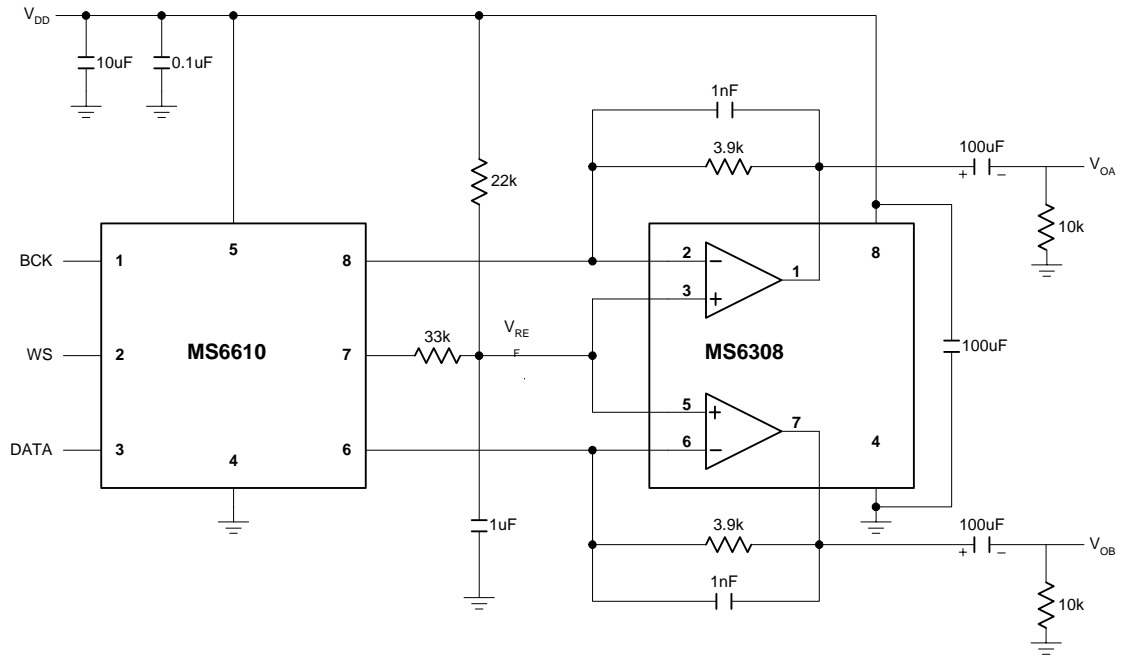

Fig.5 A first order lowpass filter for DAC output with MS6323

Example of application with MS6610 (current output)



EXTERNAL DIMENSIONS

SOP8

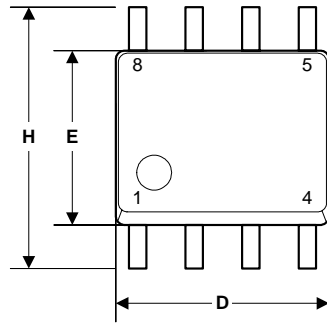

Symbol	Dimension in mm		Dimension in inch	
	Min	Max	Min	Max
A	1.35	1.75	0.0532	0.0688
A1	0.10	0.25	0.0040	0.0098
B	0.33	0.51	0.013	0.020
C	0.19	0.25	0.0075	0.0098
D	4.80	5.00	0.1890	0.1968
H	5.80	6.20	0.2284	0.2440
E	3.80	4.00	0.1497	0.1574
e	1.27 BSC		0.050 BSC	
L	0.40	1.27	0.016	0.050

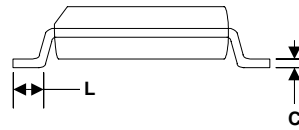
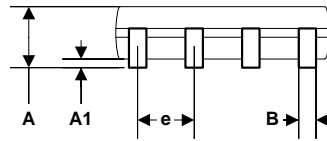

MSOP8 (Thermal Pad)

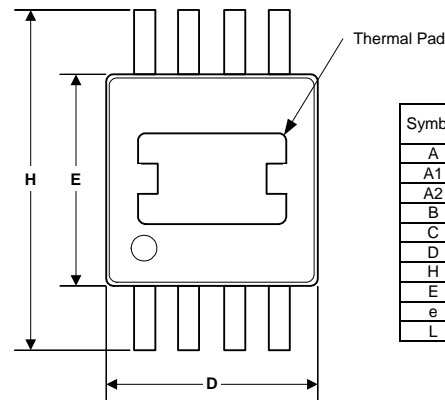

Symbol	Dimension in mm		Dimension in inch	
	Min	Max	Min	Max
A	0.81	1.12	0.032	0.048
A1	0.05	0.15	0.002	0.006
A2	0.76	0.86	0.030	0.038
B	0.28	0.38	0.011	0.015
C	0.13	0.23	0.005	0.009
D	2.90	3.10	0.114	0.122
H	4.70	5.10	0.185	0.201
E	2.90	3.10	0.114	0.122
e	0.65		0.026	
L	0.40	0.66	0.016	0.026

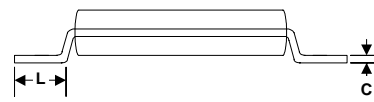
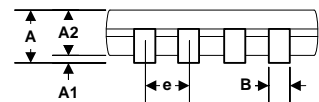

Note : Die pad exposure size is according to lead frame design.

TAPE AND REEL (Unit : mm)

