



ADVANCED QAMLINK® DOCSIS® 2.0 HIGH-PERFORMANCE, SINGLE-CHIP CABLE MODEM

FEATURES

- State of the art, single chip DOCSIS®/EuroDOCSIS™ 2.0 cable modem providing unprecedented levels of integration and performance
- The BCM3349 integrates:
 - Advanced QAMLink® transceiver supporting Annex A/B/C operation
 - DOCSIS/EuroDOCSIS 2.0 MAC with 6 SIDS
 - High performance 200 MHz MIPS32 CPU
 - Advanced QAMLink, downstream demodulator, supporting 4/16/32/64/128/256/512/1024-QAM
 - Advanced QAMLink, upstream modulator, supporting 2/4/8/16/64/128/256-QAM with S-CDMA
 - Upstream power amplifier
 - 10/100 Ethernet MAC/PHY with MII interface
 - Single 28 MHz reference crystal
 - USB 1.1 slave port with integrated transceiver
 - 100 MHz SDRAM interface
- Advanced RF and control interface to silicon tuner for DOCSIS/EuroDOCSIS solutions
- EJTAG embedded ICE support
- On-chip support for Propane® packet acceleration
- Sixth-generation technology
- On-chip regulation support single voltage operation
- 316-pin PBGA package

SUMMARY OF BENEFITS

- Results in simplified BOM—optimized for two layer PCB designs, reduces component count, improves assembly process and results in lowest overall system cost for DOCSIS/EuroDOCSIS 2.0 cable modem
- DOCSIS 2.0/1.1 MAC provides compatibility with existing CM applications code resulting in minimum time-to-market
- 200 MHz MIPS32 CPU provides 270 DMIPS 30-50% improvement in packet throughput over previous generations
- Advanced QAMLink modulator/demodulator provides superior performance in noisy plant environment
- 6 downstream SIDS and 16 upstream queues allow for improved simultaneous support for high QoS and BE traffic
- On-chip Propane supports DOCSIS/EuroDOCSIS compatible packet acceleration
- Integrated 10/100 Ethernet MAC/PHY with MII eliminates the need for external Ethernet support
- Fully USB 1.1 compliant interface enables simple Plug and Play installations
- EJTAG embedded ICE support is compatible with existing MIPS32 development tools improving software development and testing
- Sixth-generation technology results in a highly-stable, reliable product

High-Performance, Single-Chip DOCSIS®/EuroDOCSIS™ 2.0 Cable Modem

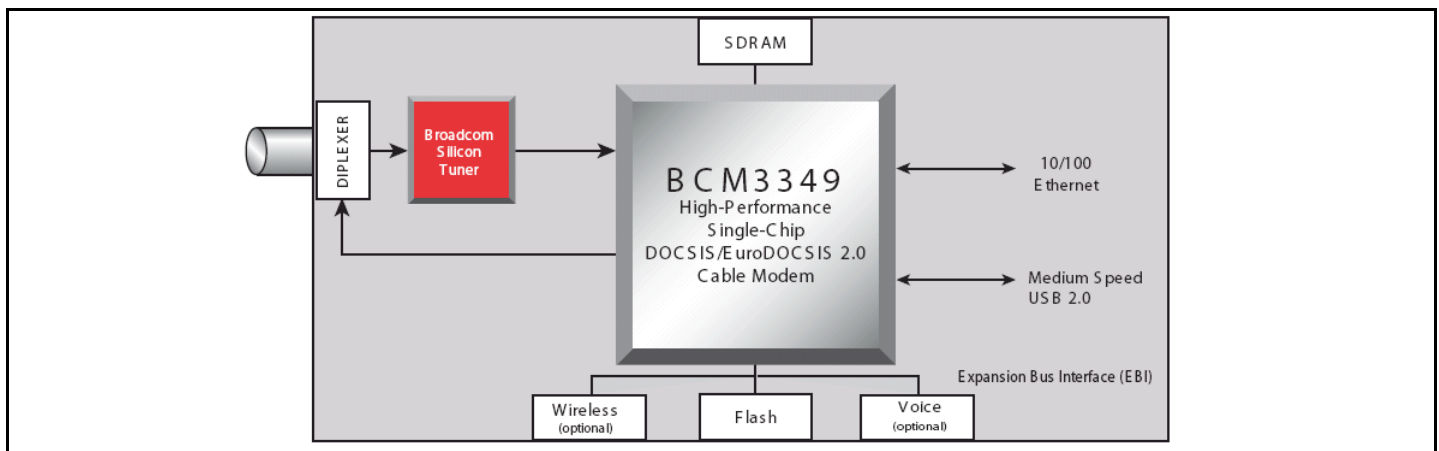

OVERVIEW

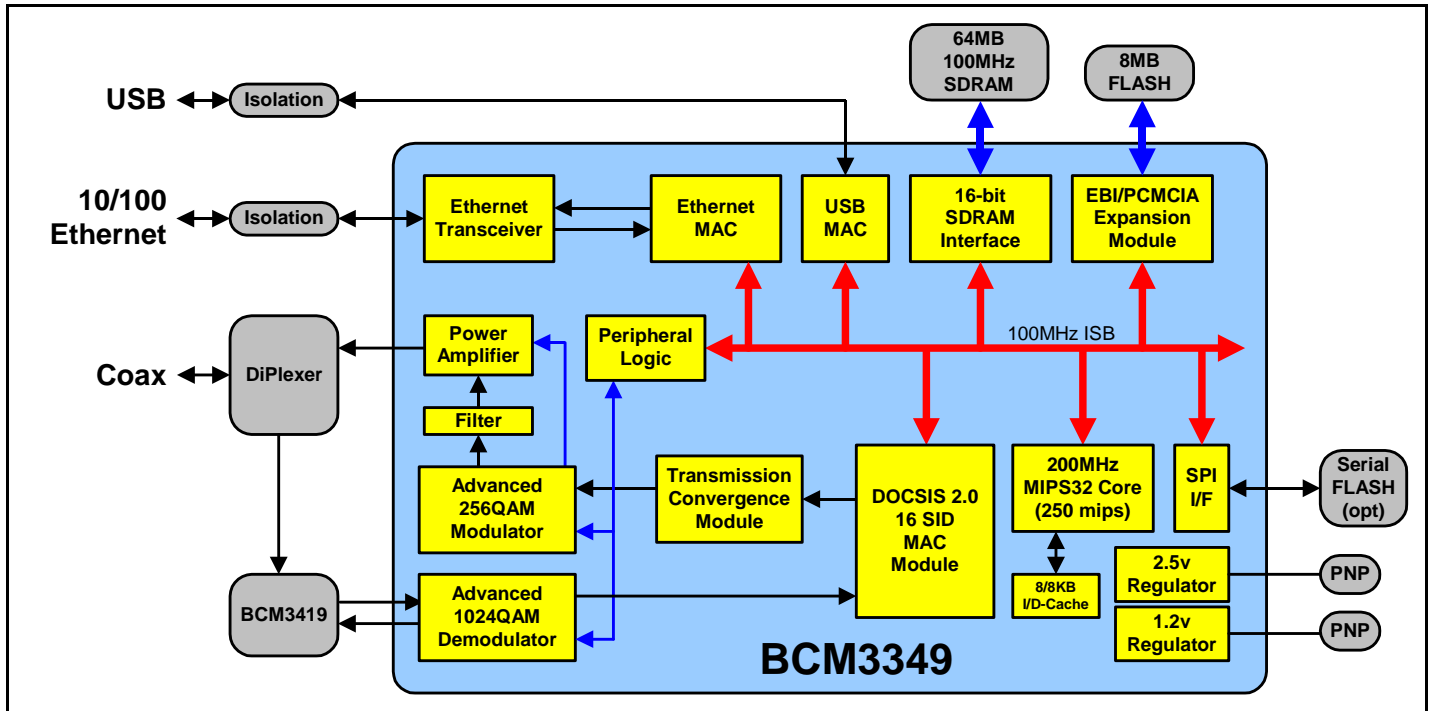

The BCM3349 combines an RF receiver with an advanced QAM and S-CDMA demodulator, an advanced QAM transmitter, a complete DOCSIS 2.0 Media Access Controller (MAC), a 200 MHz MIPS32 communication processor, a 16-bit, 100-MHz SDRAM interface, 10/100 Ethernet MAC with integrated transceiver and MII Interface, and a medium-speed USB 2.0 controller with integrated transceiver.

The QAM receiver directly samples a tuner output with a 11-bit A/D converter and input ACG amplifier. The receiver digitally resamples and demodulates the signal with recovered clock and carrier timing, filters and equalizes the data and passes soft decisions to an ITU-T J.83 Annex A/B/C compatible decoder. The receiver supports variable symbol rate 4/16/32/64/128/256/512/1024-QAM FEC decoding. The final received data stream is delivered in a serial MPEG-2 transport format. All gain, clock, and carrier, acquisition and tracking loops are integrated in the QAM receiver.

The upstream transmitter takes burst or continuous data, provides FEC encoding and pre-equalization for DOCSIS applications, filters and applies 2/4/8/16/64/128/256-QAM or S-CDMA, modulation to the data stream, amplifies the signal through the integrated upstream power amplifier and provides a direct 0 MHz – 65 MHz analog output.

The BCM3349 MAC includes all features required for full DOCSIS 1.0, 1.1 and 2.0 compliance, including full support for baseline privacy (BPI+) encryption and decryption. Single-user support includes 6 SIDS in downstream, 4 DA perfect-match filters, a 256-entry CAM for multicast/unicast hash filter, and 16 independent upstream queues for simultaneous support of QoS and BE traffic. To enhance operational support, the BCM3349 MAC provides extended network management MIB/diagnostic features, as well as immediate UCC (on-the-fly) using independent resets for downstream and upstream and both individual queue reset/flush for upstream queues. The BCM3349 uses advanced Propane techniques to provide packet acceleration to significantly improve upstream channel utilization.

The BCM3349 pinout has been optimized to allow an ultra lowcost 2-layer PCB. With the incorporation of an upstream power amplifier, the BCM3349 allows a complete cable modem to be assembled with a minimal set of external components. When used with the BCM3419 silicon tuner, the BCM3349 offers the lowest price solution for a high-performance, single-user DOCSIS 2.0 cable modem.

Broadcom[®], the pulse logo, and **Connecting everything**[®] are trademarks of Broadcom Corporation and/or its subsidiaries in the United States and certain other countries. All other trademarks mentioned are the property of their respective owners.

Connecting
everything[®]



BROADCOM CORPORATION
16215 Alton Parkway, P.O. Box 57013
Irvine, California 92619-7013

© 2003 by BROADCOM CORPORATION. All rights reserved.

Phone: 949-450-8700
Fax: 949-450-8710
E-mail: info@broadcom.com
Web: www.broadcom.com