



## ADVANCED LOW-IF DIRECT CONVERSION CABLE TUNER

### FEATURES

- Supports DOCSIS 2.0 and EuroDOCSIS 1.1
- Supports 64, 256, and 1024 QAM
- Input frequency range of 50 MHz through 860 MHz \*
- IF output range of 4 MHz, 4.5 MHz, and 5 MHz
- High linearity across entire frequency range
- Differential signals for high noise immunity
- Eliminates need for image reject mixer
- Highly integrated and cost-effective
  - Minimal BOM with reference designs available
  - True single-chip tuner
  - Single 3.3V supply voltage
  - Fully integrated oscillator
  - Fully integrated channel selectivity
  - Provides Received Signal Strength Information (RSSI) through I<sup>2</sup>C bus
  - 40-pin MLF Package

\* = For use only in applications where the input frequency to the diplexer is less than 1000 MHz.

### SUMMARY OF BENEFITS

- DOCSIS and EuroDOCSIS 1.0/1.1/2.0 compliant
- Minimal in-house RF expertise required
- Superior alternative to can tuners
  - High quality and reliability (no hand tweaking)
  - Enables lower profile and smaller designs
  - Simplified manufacturing flow
  - Lower BOM cost
- Eliminates many external components:
  - SAW IF filters
  - RSSI measurement components
  - IF amplifiers
  - Oscillator components
- RF Splitter provides for loop-through or out-of-band receiver functions
  - Single 3.3V supply voltage provides low power operation

### APPLICATIONS

- Cable Modems

### Tuner Application Example (Cable Modem)

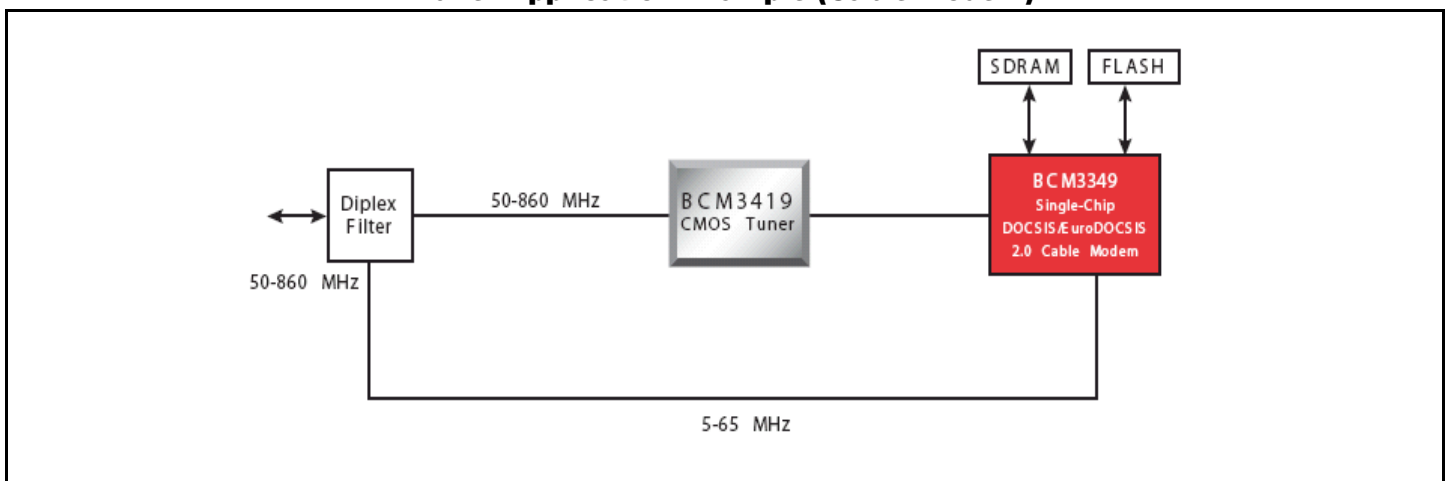

# OVERVIEW

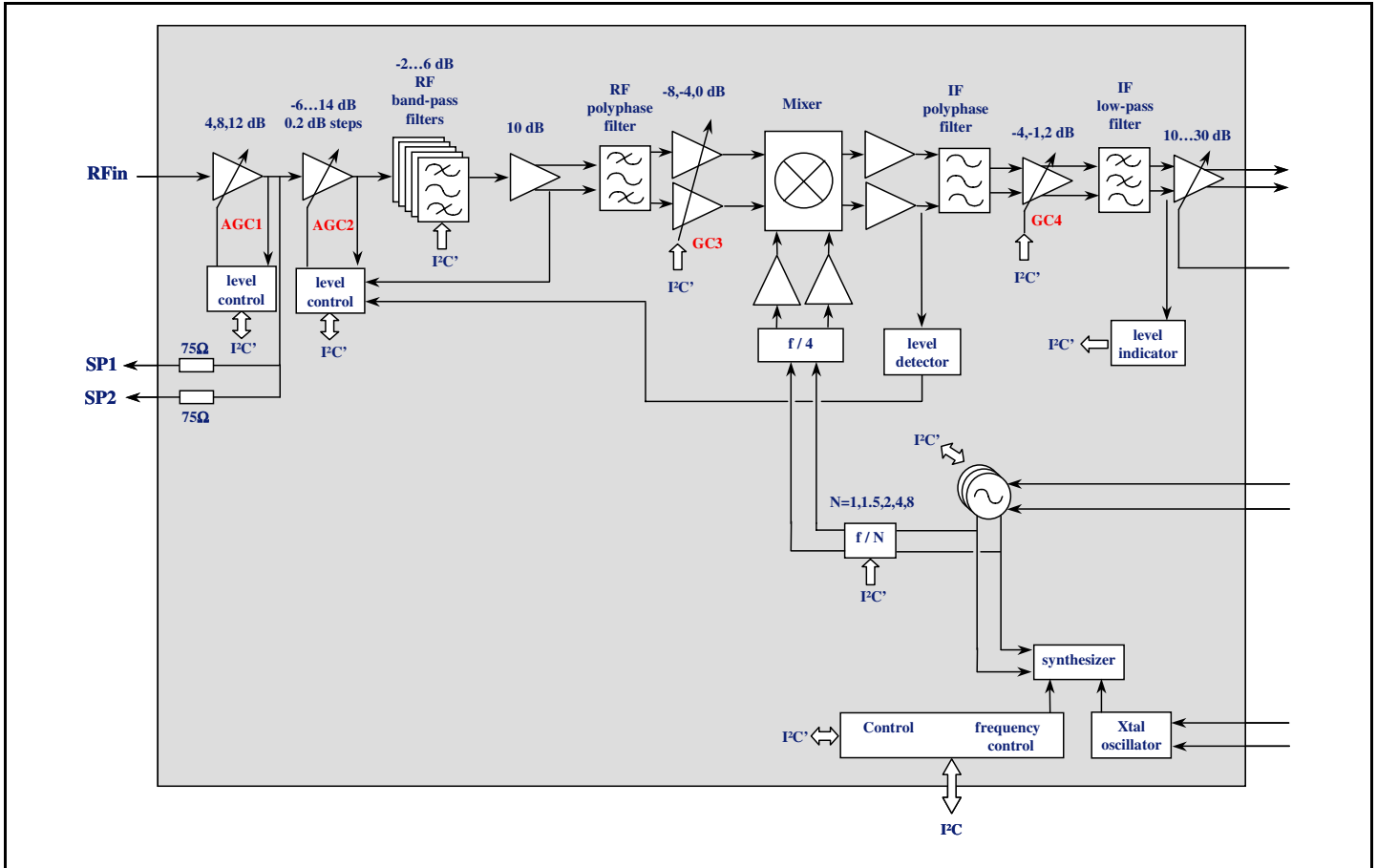

The BCM3419 is a highly integrated single-chip silicon tuner. This solution supports both 64-QAM, 256-QAM, and 1024-QAM digital cable modem applications.

The BCM3419 is specifically designed to work with Broadcom's industry-leading BCM3349 single-chip cable modem, and form an attractive alternative to traditional can tuners and previous generations of silicon tuners in any cable modem design.

The BCM3419 supports an IF output frequency range of 4 MHz, 4.5 MHz, and 5 MHz. These choices allow the BCM3419 to support both DOCSIS and EuroDOCSIS standards.

Great care was taken to develop the proven reference designs, which also minimize the external components required. This system's expertise allows our customers to design with confidence even if they have minimal in-house RF expertise, while lowering their overall BOM cost versus the traditional can tuners.

Broadcom®, the pulse logo, and Connecting everything® are trademarks of Broadcom Corporation and/or its subsidiaries in the United States and certain other countries. All other trademarks mentioned are the property of their respective owners.

Connecting  
everything®



**BROADCOM CORPORATION**  
16215 Alton Parkway, P.O. Box 57013  
Irvine, California 92619-7013

© 2004 by BROADCOM CORPORATION. All rights reserved.

Phone: 949-450-8700  
Fax: 949-450-8710  
E-mail: info@broadcom.com  
Web: www.broadcom.com